

15kV 200AMP Bushing Insert

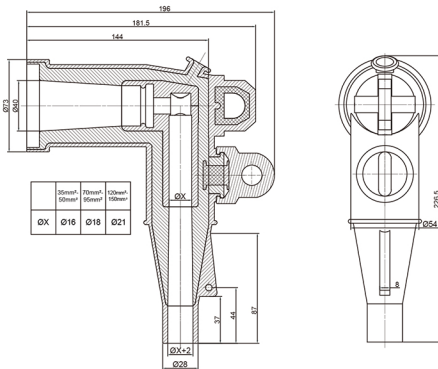

- Elbow connector, test point cap, grounding wire, loadbreak brand
- Loadbreak probe • Probe installation tool • Silicone lubricant
- Conducot cable lug • Clearing paper

Description

15kV 200A Load break Elbow Connector is a fully-shielded and insulated plug-in termination for connecting underground cable to distribution power system of pad-mound transformer, surrounding power supply branch box, cable branch box equipped with load break bushings. The elbow connector and bushing insert comprise the essential components of all load break connections. It can meet the demand of lines in nuclear.

The Load break Elbows are molded using high quality sulfur-cured insulation and semi-conducting EPDM rubber. Standard features include a coppertop connector tin-plated copper load break probe with an ablative arc-follower tip and stainless steel reinforced pulling-eye. An optional capacitive test point, made of corrosion resistant plastic, is available for Use with fault indicators. The available conductor cross section is 35-150mm² for 15kV cable. The conductive pole W/ARC extinguishes function.

Specifications

Description	Units	Ratings
Voltage Class	kV	15 kV
Voltage Rating	kV	8.3/14.4 kV
Rated Current	kV	200 A
AC Withstand Voltage 1 min	kV	45 kV
DC Withstand Voltage 1 min	kV	53 kV
Partial Discharge	kV	15 kV, ≤10 pC
BIL	A	95 kV

Product Structure

1. PULLINGEYE: Stainless steel reinforced for positive shotgun stick switching operations.
2. INSULATION: High-quality EPDM rubber formulated, mixed, and milled in-house for consistent and reliable field performance.
3. SEMI-CONDUCTIVE INSERT: High-quality EPDM rubber creates a smooth surface around the "current interchange" to evenly distribute electrical stress within the insulation.
4. TEST POINT(OPTIONAL): Corrosion-resistan, conductive electrode provides consistent capacitive voltage for application of fault indicators and determining a circuit's state (cap not shown)
5. SEMI-CONDUCTIVE SHIELD: High-quality EPDM rubber provides protective dead front shield that meets requirements of IEEE Standard 592.
6. LOADBREAK PROBE: Tin-plated copper probe with arc-ablative tip(arc follower)
7. CONDUCTOR CABLE LUG: Inertia-welded aluminum barrel and threaded copper lug makes crimping easy and ensures a tight, reliable electrical connection with load break probe. Standard IEEE and CSA types available.